

SECTION

# 2



2

## Lever Type Dial Indicators Pic Test • New Pic Test

- PCN Series
- W Series
- Z Series
- E Series
- U Series
- D Series
- PC Series
- R Series **"NEW"**
- V Series
- DS8V Series **"NEW"**
- Accessories
- PK-TEST

HARDINGE TECHNOLOGY

# Lever Type Dial Indicators NEW PIC TEST

## Without change lever PCN series

The New Pic Test is a lever type dial indicators used in all over the world. It is a measuring instrument used for measurements of restricted areas, and the outside/inside, groove width and centering with the dial gauge installed to the lathe or the milling cutting machine for measurements with the gauges held on the height gauges.

- **Without change lever (Automatic inverse type)**  
The lever type dial gauge of this type has no change lever, the contact point inverses automatically in normal or reverse direction as desired and pointer turns always CW to improve the measuring efficiency.
- **Miniature Bearing Used**  
The miniature bearing used as a bearing at the pivot of the contact point to show good indication stability without any effect by rod play.
- **O-ring used**  
Oil resistance is enhanced by seating the O-ring in the turning section of the outer frame.



**PCN-0**  
Graduation: 0.01mm  
Range: 0.5mm  
● Small dial face (φ 29)  
● Contact Point No. XN1A-2

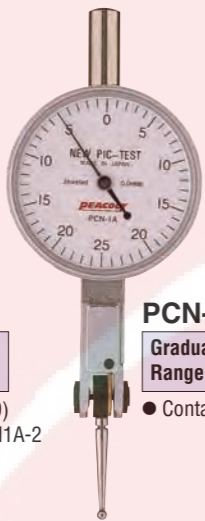

**PCN-1A**  
Graduation: 0.01mm  
Range: 0.5mm  
● Contact Point No. XN1A-2

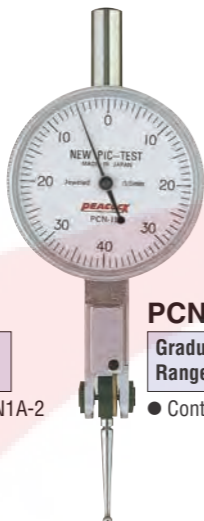

**PCN-1B**  
Graduation: 0.01mm  
Range: 0.8mm  
● Contact Point No. XN1B-2

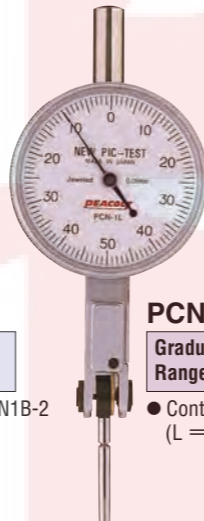

**PCN-1L**  
Graduation: 0.01mm  
Range: 1.0mm  
● Contact Point No. XN1L-2 (L = 42.8mm)

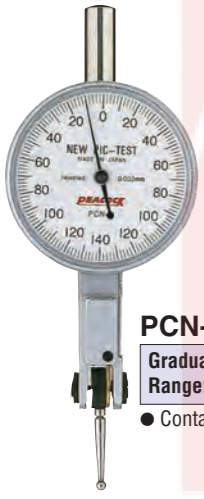

**PCN-2**  
Graduation: 0.002mm  
Range: 0.28mm  
● Contact Point No. XN2-2

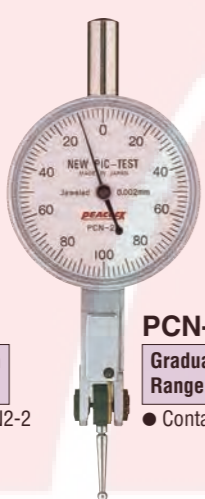

**PCN-2B**  
Graduation: 0.002mm  
Range: 0.2mm  
● Contact Point No. XN2B-2



**PCN-S**  
Graduation: 0.001mm  
Range: 0.14mm  
● High accuracy  
● Contact Point No. XNS-2



**PCN-7A**  
Graduation: 0.01mm  
Range: 1.5mm  
● Wide measuring range  
● with Shorter Pointer  
● Contact Point No. XN1A-2



**PCN-7C**  
Graduation: 0.002mm  
Range: 0.6mm  
● Wide measuring range  
● with Shorter Pointer  
● Contact Point No. XN2B-2

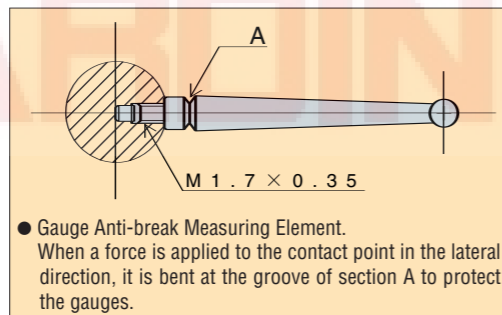

※ The contact point can simply replaced (See page P58).

Vertical



**PCN-5**  
Graduation: 0.01mm  
Range: 0.5mm  
● Contact Point No. XN1A-2

Vertical



**PCN-6**  
Graduation: 0.002mm  
Range: 0.28mm  
● Contact Point No. XN2-2

New

Vertical



**PCN-6S**  
Graduation: 0.001mm  
Range: 0.14mm  
● Contact Point No. XNS-2

### Specifications

Model	Graduation (mm)	Range (mm)	Reading	Accuracy MPE (μm)					Measuring force less than(N)
				10 Scale	1 Rev.	Wide-range Forward accuracy	Hysteresis	Repeatability	
PCN-0	0.01	0.5	0 - 25 - 0	5	—	6	4	3	0.3
PCN-1A	0.01	0.5	0 - 25 - 0	5	—	6	4	3	0.3
PCN-1B	0.01	0.8	0 - 40 - 0	5	—	9	4	3	0.3
PCN-1L	0.01	1.0	0 - 50 - 0	5	—	10	5	3	0.3
PCN-2	0.002	0.28	0 - 140 - 0	2	—	4	3	1	0.3
PCN-2B	0.002	0.2	0 - 100 - 0	2	—	4	3	1	0.3
PCN-S	0.001	0.14	0 - 70 - 0	2	—	4	3	1	0.3
PCN-7A	0.01	1.5	0 - 25 - 0	5	10	16	5	3	0.3
PCN-7C	0.002	0.6	0 - 100 - 0	2	5	7	4	1	0.3
PCN-5	0.01	0.5	0 - 25 - 0	5	—	6	4	3	0.3
PCN-6	0.002	0.28	0 - 140 - 0	2	—	4	3	1	0.3
PCN-6S	0.001	0.14	0 - 70 - 0	2	—	4	3	1	0.3

## Special Type Test Indicators

### Double Dial Type W series

- The conventional lever type dial gauge used to have some unreadable points when aligning with it, which has made it impossible to do the accurate aligning till now. The double dial type Pic Test has two dials at both sides, making it possible to cover said unreadable points by conventional Pic Tests.



**PC-1BW**  
Graduation: 0.01mm  
Range: 0.8mm  
● Change lever type  
● Contact Point No. XP1B-2

### Alignment work

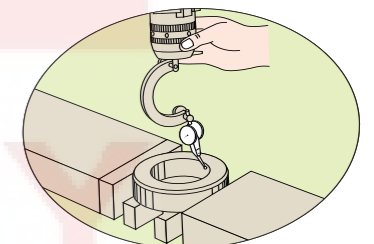

With Dual dial type, readings can be made easily even if gauges is turned 180 deg.

### Specifications

Model	Graduation (mm)	Range (mm)	Reading	Accuracy MPE (μm)					Measuring force less than(N)
				10 Scale	1 Rev.	Wide-range Forward accuracy	Hysteresis	Repeatability	
PC-1BW	0.01	0.8	0 - 40 - 0	5	—	9	4	3	0.4

# Special Type Test Indicators

## One Revolution Z series (without change lever type)

The dial face is easy to read with light yellow and blue (dead zone)

- Gauge Anti-break Measuring Element**  
When a force is applied to the contact point in the lateral direction, it is bent at the groove of section A to protect the gauge. The contact point can simply be replaced (adopted in all the PCN and PC).
- Dial face with colored limit**  
To check out of tolerance detection and testing easier.
- Dust and Oil resistant O-ring (inside bezel)**  
Oil resistance is enhanced by seating the O-ring in the turning section of the outer frame.
- Super sensitive miniature bearing used**  
The miniature bearing is used as a bearing at the pivot of the contact point to show stable indication without any effect by rod play.
- No clutch (automatic inverse type)**  
The Pic Test Indicator of this type has no bias lever, the contact point inverse automatically in the normal or reverse direction as desired and the pointer turns always CW to improve the measuring efficiency.
- φ6mm SK quenched stem**

### "A" type Downward



**PCN-1BZ(A)**  
Graduation: 0.01mm  
Range: 0.6mm  
● Contact Point No. XN1B-2



**PCN-1LZ(A)**  
Graduation: 0.01mm  
Range: 0.8mm  
● Contact Point No. XN1L-2



**PCN-2Z(A)**  
Graduation: 0.002mm  
Range: 0.2mm  
● High accuracy  
● Contact Point No. XN2-2

### Specifications

Model	Graduation (mm)	Range (mm)	Movable Range (mm)	Accuracy MPE (μm)					Measuring force less than(N)
				10 Scale	1 Rev.	Wide-range Forward accuracy	Hysteresis	Repeatability	
PCN-1BZ(A)	0.01	0.6	0.7	5	—	9	4	3	0.3
PCN-1LZ(A)	0.01	0.8	0.9	5	—	10	5	3	0.3
PCN-2Z(A)	0.002	0.2	0.24	2	—	4	3	1	0.3

### "B" type Upward



**PCN-1BZ(B)**  
Graduation: 0.01mm  
Range: 0.6mm  
● Contact Point No. XN1B-2

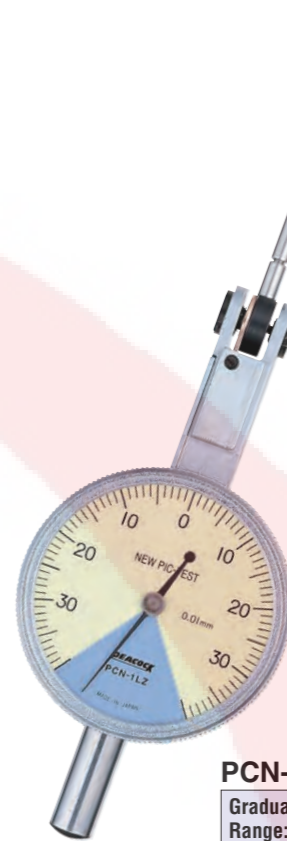

**PCN-1LZ(B)**  
Graduation: 0.01mm  
Range: 0.8mm  
● Contact Point No. XN1L-2



**PCN-2Z(B)**  
Graduation: 0.002mm  
Range: 0.2mm  
● High accuracy  
● Contact Point No. XN2-2

### Specifications

Model	Graduation (mm)	Range (mm)	Movable Range (mm)	Accuracy MPE (μm)					Measuring force less than(N)
				10 Scale	1 Rev.	Wide-range Forward accuracy	Hysteresis	Repeatability	
PCN-1BZ(B)	0.01	0.6	0.7	5	—	9	4	3	0.3
PCN-1LZ(B)	0.01	0.8	0.9	5	—	10	5	3	0.3
PCN-2Z(B)	0.002	0.2	0.24	2	—	4	3	1	0.3

### Dimensions

**Length of Contact Point**

Model	L (mm)
PCN-1BZ(A) PCN-1BZ(B)	22.2
PCN-2Z(A) PCN-2Z(B)	17.94
PCN-1LZ(A) PCN-1LZ(B)	42.8

HARDINGE TECHNOLOGY

# Special Type Test Indicators

## Super low measuring force E series

Lever dial gauge that is suitable for flaw-free measure of an object under measurement and for measurement of plastic products with a low measuring force.  
A measuring force is 0.05N, 0.1N or less that is lower than a 0.4N measuring force in the conventional dial gauges.  
Specifications and outer dimensions are the same as those of standard PC and PCN types, except a measuring force.

### Without change lever type (CW rotation only)

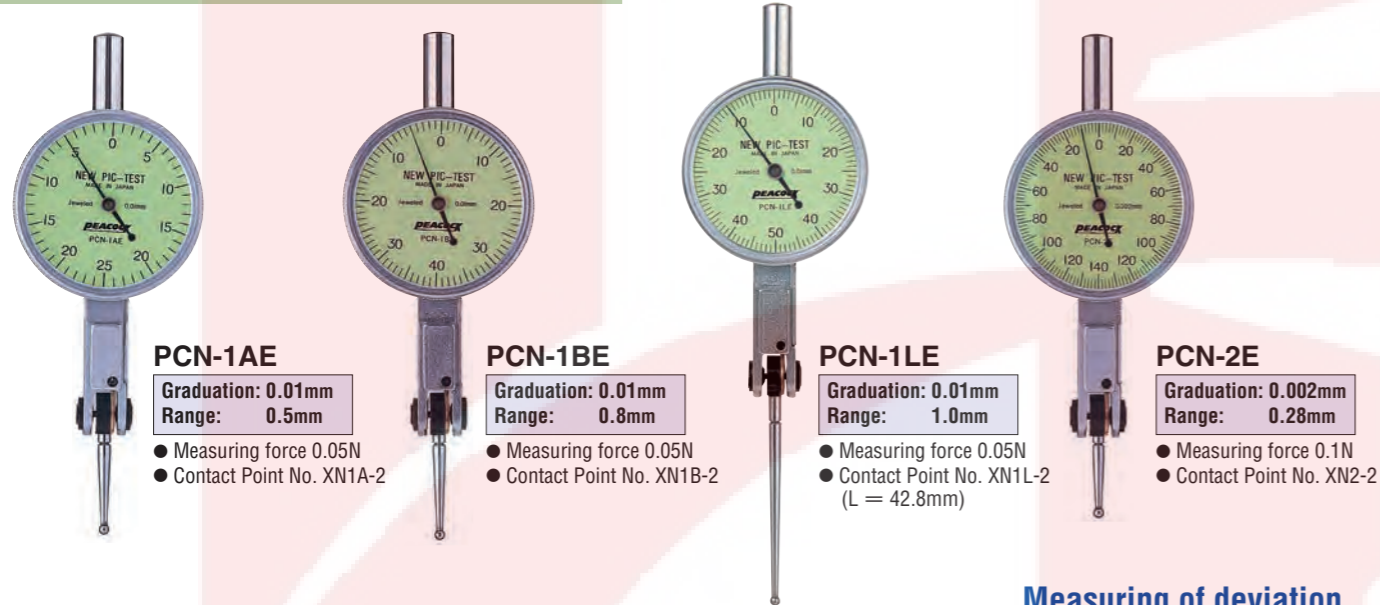

### Change lever type

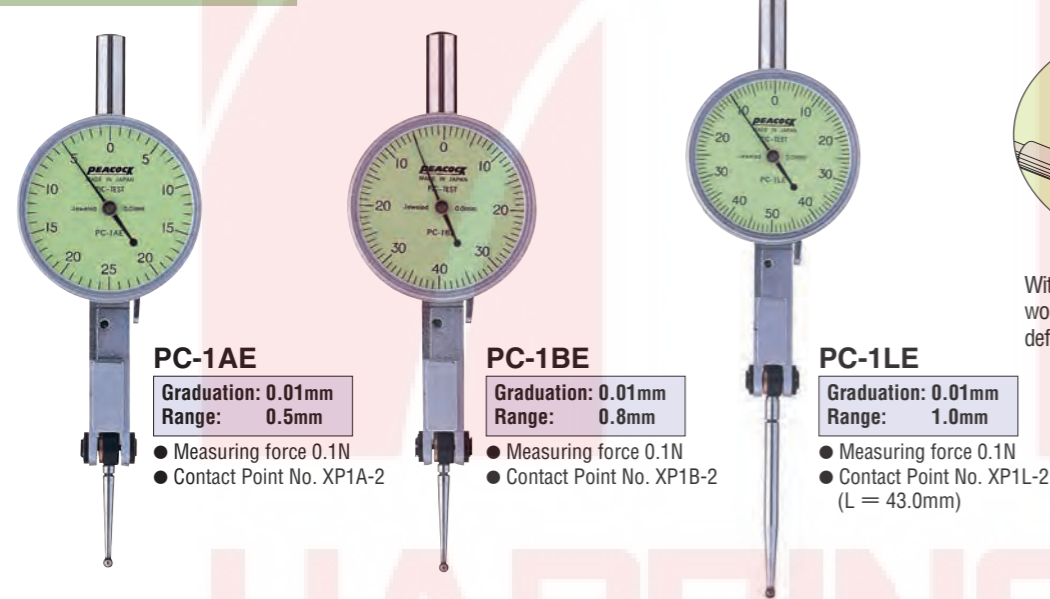

### Measuring of deviation on rubber roller

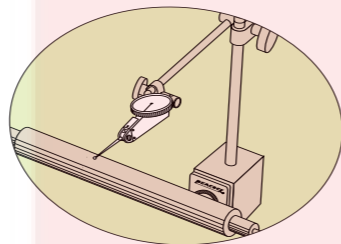

With extra low measuring force, work piece can be measured without deforming it.

### Specifications

Model	Graduation (mm)	Range (mm)	Reading	Accuracy MPE (μm)					Measuring force less than(N)
				10 Scale	1 Rev.	Wide-range Forward accuracy	Hysteresis	Repeatability	
PCN-1AE	0.01	0.5	0 - 25 - 0	5	—	6	4	3	0.05
PCN-1BE	0.01	0.8	0 - 40 - 0	5	—	9	4	3	0.05
PCN-1LE	0.01	1.0	0 - 50 - 0	5	—	10	5	3	0.05
PCN-2E	0.002	0.28	0 - 140 - 0	2	—	4	3	1	0.1
PC-1AE	0.01	0.5	0 - 25 - 0	5	—	6	4	3	0.1
PC-1BE	0.01	0.8	0 - 40 - 0	5	—	9	4	3	0.1
PC-1LE	0.01	1.0	0 - 50 - 0	5	—	10	5	3	0.1

# Special Type Test Indicators

## Non-electrifying & Complete Anti-magnetic U series

When non-electrifying type of Pic Test or New Pic Test is used, electric flow is blocked at the ceramic stem, even of a magnetic stand is electrified. Thus, you can continue your work without any problem.  
The dial face is light blue color and easy to read.  
Specifications and outer dimensions are the same as those of standard PCN types, except the portion of stems.

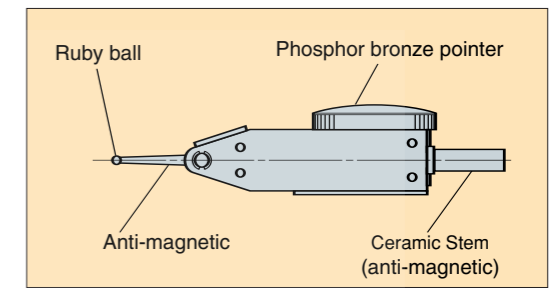

### Without change lever type (CW rotation only)

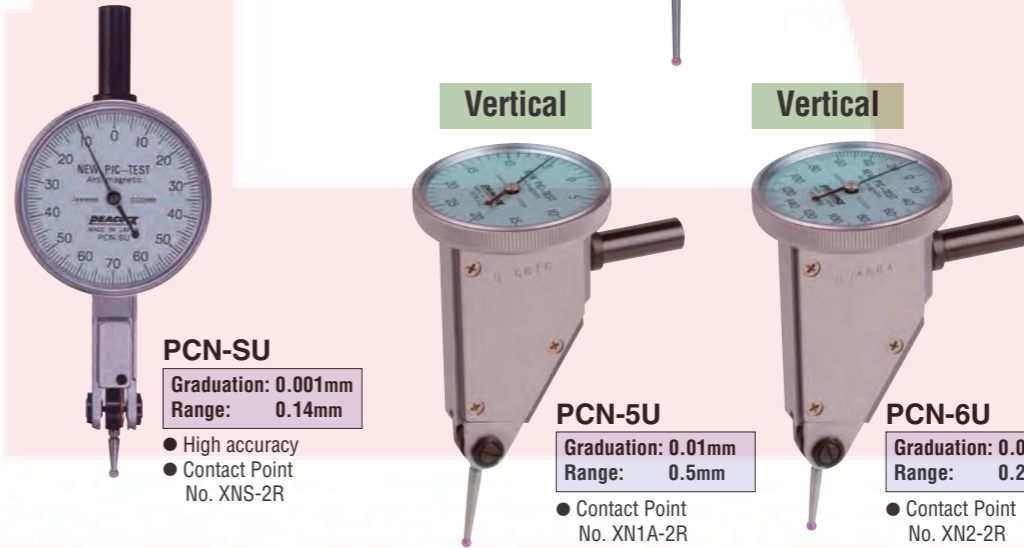
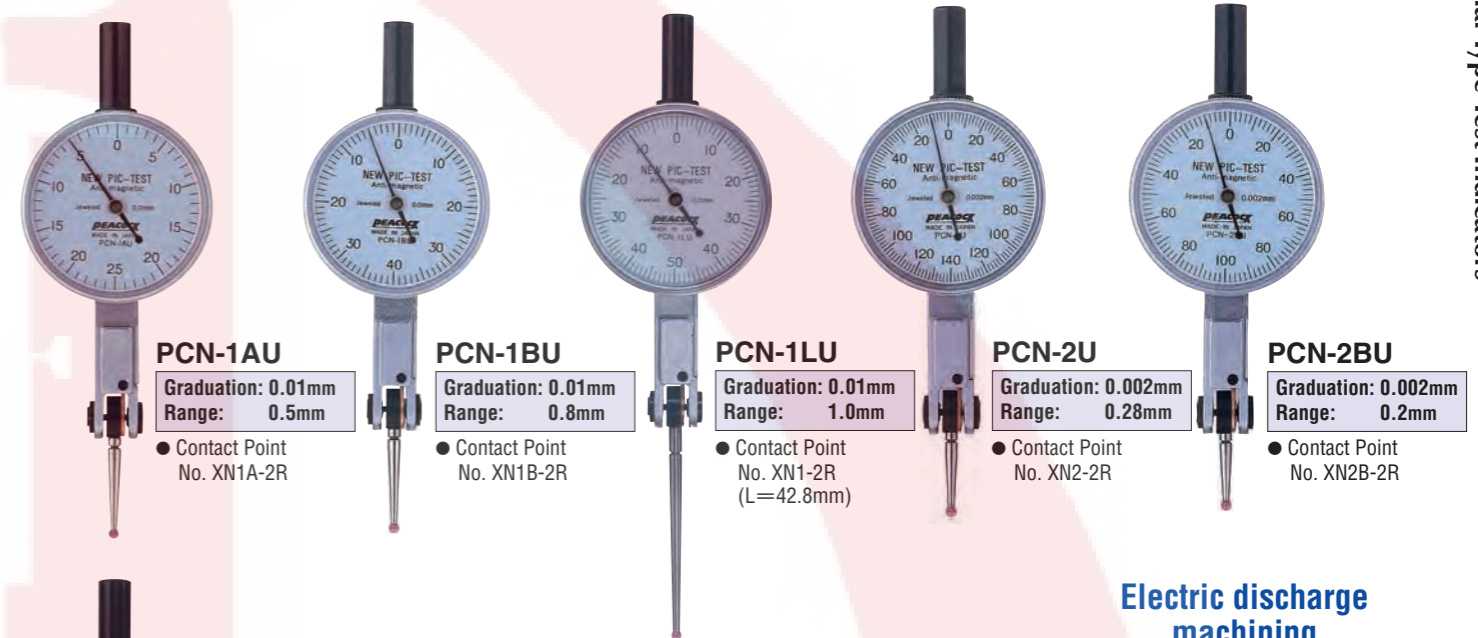

### Electric discharge machining

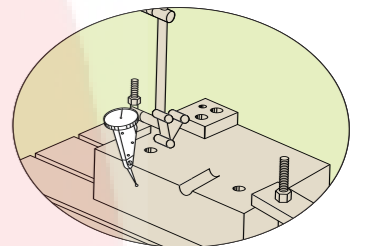

Ceramic stem is supported by a magnetic stand. Electric current is isolated by the ceramic stem. It is thus possible to measure the work piece without electrifying it.

### Specifications

Model	Graduation (mm)	Range (mm)	Reading	Accuracy MPE (μm)					Measuring force less than(N)
				10 Scale	1 Rev.	Wide-range Forward accuracy	Hysteresis	Repeatability	
PCN-1AU	0.01	0.5	0 - 25 - 0	5	—	6	4	3	0.3
PCN-1BU	0.01	0.8	0 - 40 - 0	5	—	9	4	3	0.3
PCN-1LU	0.01	1.0	0 - 50 - 0	5	—	10	5	3	0.3
PCN-2U	0.002	0.28	0 - 140 - 0	2	—	4	3	1	0.3
PCN-2BU	0.002	0.2	0 - 100 - 0	2	—	4	3	1	0.3
PCN-SU	0.001	0.14	0 - 70 - 0	2	—	4	3	1	0.3
PCN-5U	0.01	0.5	0 - 25 - 0	5	—	6	4	3	0.3
PCN-6U	0.002	0.28	0 - 140 - 0	2	—	4	3	1	0.3

# Special Type Test Indicators

## Large dial face D series

The dial plate size of PCN-1A, PCN-1L, PCN-2B, and PCN-S models has been enlarged, with easy reading due to the larger scale spacing, as a result. Screw type long stems are standard for these large dial face test indicators.

Without change lever type (CW rotation only)



**PCN-1AD**  
Graduation: 0.01mm  
Range: 0.5mm  
● Contact Point No. XN1A-2



**PCN-1LD**  
Graduation: 0.01mm  
Range: 1mm  
● Contact Point No. XN1L-2 (L = 42.8mm)



**PCN-2BD**  
Graduation: 0.002mm  
Range: 0.2mm  
● Contact Point No. XN2B-2

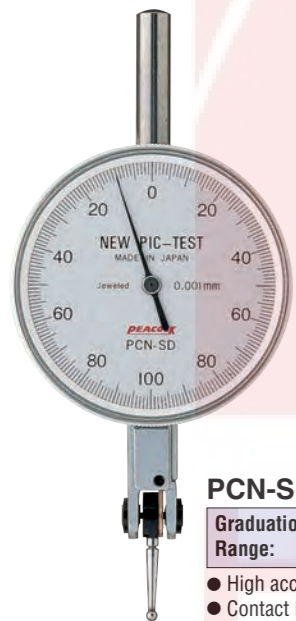

**PCN-SD**  
Graduation: 0.001mm  
Range: 0.2mm  
● High accuracy  
● Contact Point No. XN2B-2

Easy to read

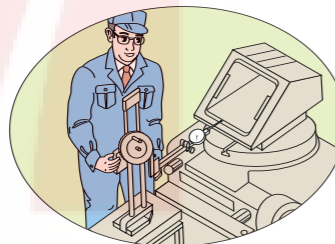

An enlarge dial face with bigger scale intervals enables easy reading by user of all ages.

Large Size Dial Face

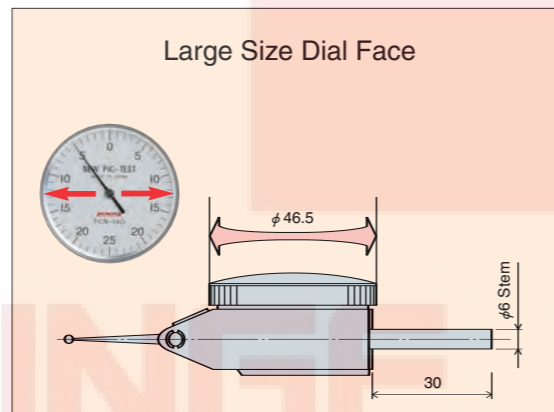

### Specifications

Model	Graduation (mm)	Range (mm)	Reading	Accuracy MPE (μm)					Measuring force less than(N)
				10 Scale	1 Rev.	Wide-range Forward accuracy	Hysteresis	Repeatability	
PCN-1AD	0.01	0.5	0 - 25 - 0	5	—	6	4	3	0.3
PCN-1LD	0.01	1.0	0 - 50 - 0	5	—	10	5	3	0.3
PCN-2BD	0.002	0.2	0 - 100 - 0	2	—	4	3	1	0.3
PCN-SD	0.001	0.2	0 - 100 - 0	2	—	4	3	1	0.3

# Lever Type Dial Indicators PIC TEST

## Change lever type PC series

- Miniature Bearing Used  
The miniature bearing used as a bearing at the pivot of the contact point to show good indication stability without any effect by rod play.
- O-ring used  
Oil resistance is enhanced by seating the O-ring in the turning section of the outer frame.

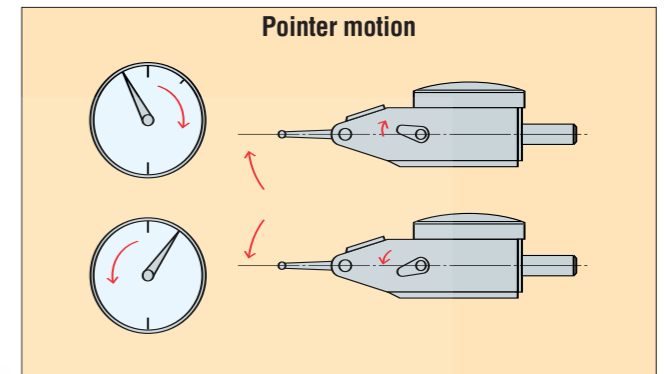

**PC-1A**  
Graduation: 0.01mm  
Range: 0.5mm  
● Contact Point No. XP1A-2



**PC-1B**  
Graduation: 0.01mm  
Range: 0.8mm  
● Contact Point No. XP1B-2



**PC-1L**  
Graduation: 0.01mm  
Range: 1.0mm  
● Contact Point No. XP1L-2 (L = 43.0mm)



**PC-2**  
Graduation: 0.002mm  
Range: 0.28mm  
● Contact Point No. XP2-2



**PC-3**  
Graduation: 0.01mm  
Range: 0.5mm  
● Contact Point No. XP1A-2



**PC-3L**  
Graduation: 0.01mm  
Range: 1.0mm  
● Contact Point No. XP1L-2



**PC-4**  
Graduation: 0.002mm  
Range: 0.28mm  
● Contact Point No. XP2-2

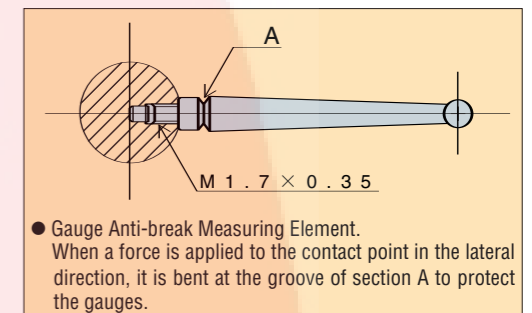

● Gauge Anti-break Measuring Element.  
When a force is applied to the contact point in the lateral direction, it is bent at the groove of section A to protect the gauges.

※ The contact point can simply be replaced (See page P58).

### Specifications

Model	Graduation (mm)	Range (mm)	Reading	Accuracy MPE (μm)					Measuring force less than(N)
				10 Scale	1 Rev.	Wide-range Forward accuracy	Hysteresis	Repeatability	
PC-1A	0.01	0.5	0 - 25 - 0	5	—	6	4	3	0.4
PC-1B	0.01	0.8	0 - 40 - 0	5	—	9	4	3	0.4
PC-1L	0.01	1.0	0 - 50 - 0	5	—	10	5	3	0.4
PC-2	0.002	0.28	0 - 140 - 0	2	—	4	3	1	0.4
PC-3	0.01	0.5	0 - 25 - 0	5	—	6	4	3	0.4
PC-3L	0.01	1.0	0 - 50 - 0	5	—	10	5	3	0.4
PC-4	0.002	0.28	0 - 140 - 0	2	—	4	3	1	0.4

# PIC TEST/NEW PIC TEST PC · PCN

New

## PIC TEST/NEW PIC TEST with Ruby ball Contact Point "R" series (Contact Point ball dia. 2mm Only)

- Excellent wear resistance
- Non-electrifying and Anti-magnetic
- Can be used on Electrical Discharge Machine

Ruby ball Contact Point

### Horizontal

**PC-1AR**  
Graduation: 0.01mm  
Range: 0.5mm  
● Change Lever type  
● Contact Point No. XP1A-2R

**PC-1BR**  
Graduation: 0.01mm  
Range: 0.8mm  
● Change Lever type  
● Contact Point No. XP1B-2R

**PC-1LR**  
Graduation: 0.01mm  
Range: 1.0mm  
● Change Lever type  
● Contact Point No. XP1L-2R

**PC-2R**  
Graduation: 0.002mm  
Range: 0.28mm  
● Change Lever type  
● High accuracy  
● Contact Point No. XP2-2R

**PCN-1AR**  
Graduation: 0.01mm  
Range: 0.5mm  
● Without Change Lever type  
● Contact Point No. XN1A-2R

**PCN-1BR**  
Graduation: 0.01mm  
Range: 0.8mm  
● Without Change Lever type  
● Contact Point No. XN1B-2R

**PCN-1LR**  
Graduation: 0.01mm  
Range: 1.0mm  
● Without Change Lever type  
● Contact Point No. XN1L-2R

**PCN-2R**  
Graduation: 0.002mm  
Range: 0.28mm  
● Without Change Lever type  
● High accuracy  
● Contact Point No. XN2-2R

**PCN-2BR**  
Graduation: 0.002mm  
Range: 0.2mm  
● Without Change Lever type  
● High accuracy  
● Contact Point No. XN2B-2R

**PCN-SR**  
Graduation: 0.001mm  
Range: 0.14mm  
● Without Change Lever type  
● High accuracy  
● Contact Point No. XNS-2R

**PCN-5R**  
Graduation: 0.01mm  
Range: 0.5mm  
● Without Change Lever type  
● Contact Point No. XN1A-2R

**PCN-6R**  
Graduation: 0.002mm  
Range: 0.28mm  
● Without Change Lever type  
● High accuracy  
● Contact Point No. XN2-2R

### Vertical

### Specifications

Model	Graduation (mm)	Range (mm)	Reading	Accuracy MPE (μm)					Measuring force less than(N)
				10 Scale	1 Rev.	Wide-range Forward accuracy	Hysteresis	Repeatability	
PC-1AR	0.01	0.5	0 - 25 - 0	5	—	6	4	3	0.4
PC-1BR	0.01	0.8	0 - 40 - 0	5	—	9	4	3	0.4
PC-1LR	0.01	1.0	0 - 50 - 0	5	—	10	5	3	0.4
PC-2R	0.002	0.28	0 - 140 - 0	2	—	4	3	1	0.4
PCN-1AR	0.01	0.5	0 - 25 - 0	5	—	6	4	3	0.3
PCN-1BR	0.01	0.8	0 - 40 - 0	5	—	9	4	3	0.3
PCN-1LR	0.01	1.0	0 - 50 - 0	5	—	10	5	3	0.3
PCN-2R	0.002	0.28	0 - 140 - 0	2	—	4	3	1	0.3
PCN-2BR	0.002	0.2	0 - 100 - 0	2	—	4	3	1	0.3
PCN-SR	0.001	0.14	0 - 70 - 0	2	—	4	3	1	0.3
PCN-5R	0.01	0.5	0 - 25 - 0	5	—	6	4	3	0.3
PCN-6R	0.002	0.28	0 - 140 - 0	2	—	4	3	1	0.3

# Special Type Test Indicators

## Without fixed Stem "V" series

- **Without fixed stem**  
This is suited for users, who do not mount the indicator by fixed Stem.
- **Dovetail Stems are available**  
Mount the indicator by Dovetail on 3 positions on the body. Dovetail Stem, DS-4 (φ4), DS-6 (φ6) and DS-8 (φ8) are available as optional accessories.
- **Miniature Bearing used**  
The miniature bearing used as a bearing at the pivot of the contact point to show good indication stability.
- **Contact Point for Gauge anti-breakage**  
All of our pic test indicator has gauge anti-breakage contact point.
- **O-ring used**  
Oil resistance is enhanced by seating the O-ring between inner and outer frames.

**PC-1AV**  
Graduation: 0.01mm  
Range: 0.5mm  
● Change Lever type  
● Contact Point No. XP1A-2

**PC-1BV**  
Graduation: 0.01mm  
Range: 0.8mm  
● Change Lever type  
● Contact Point No. XP1B-2

**PC-1LV**  
Graduation: 0.01mm  
Range: 1.0mm  
● Change Lever type  
● Contact Point No. XP1L-2

**PC-2V**  
Graduation: 0.002mm  
Range: 0.28mm  
● Change Lever type  
● High accuracy  
● Contact Point No. XP2-2

**PCN-1AV**  
Graduation: 0.01mm  
Range: 0.5mm  
● Without Change Lever type  
● Contact Point No. XN1A-2

**PCN-1BV**  
Graduation: 0.01mm  
Range: 0.8mm  
● Without Change Lever type  
● Contact Point No. XN1B-2

**PCN-1LV**  
Graduation: 0.01mm  
Range: 1.0mm  
● Without Change Lever type  
● Contact Point No. XN1L-2

**PCN-2V**  
Graduation: 0.002mm  
Range: 0.28mm  
● Without Change Lever type  
● High accuracy  
● Contact Point No. XN2-2

**PCN-2BV**  
Graduation: 0.002mm  
Range: 0.2mm  
● Without Change Lever type  
● High accuracy  
● Contact Point No. XN2B-2

**PCN-SV**  
Graduation: 0.001mm  
Range: 0.14mm  
● Without Change Lever type  
● High accuracy  
● Contact Point No. XNS-2

### Specifications

Model	Graduation (mm)	Range (mm)	Reading	Accuracy MPE (μm)					Measuring force less than(N)
				10 Scale	1 Rev.	Wide-range Forward accuracy	Hysteresis	Repeatability	
PC-1AV	0.01	0.5	0 - 25 - 0	5	—	6	4	3	0.4
PC-1BV	0.01	0.8	0 - 40 - 0	5	—	9	4	3	0.4
PC-1LV	0.01	1.0	0 - 50 - 0	5	—	10	5	3	0.4
PC-2V	0.002	0.28	0 - 140 - 0	2	—	4	3	1	0.4
PCN-1AV	0.01	0.5	0 - 25 - 0	5	—	6	4	3	0.3
PCN-1BV	0.01	0.8	0 - 40 - 0	5	—	9	4	3	0.3
PCN-1LV	0.01	1.0	0 - 50 - 0	5	—	10	5	3	0.3
PCN-2V	0.002	0.28	0 - 140 - 0	2	—	4	3	1	0.3
PCN-2BV	0.002	0.2	0 - 100 - 0	2	—	4	3	1	0.3
PCN-SV	0.001	0.14	0 - 70 - 0	2	—	4	3	1	0.3

# PIC TEST / NEW PIC TEST PC • PCN

## "DS8V" series

- We can provide all of our PIC TEST/NEW PIC TEST with  $\phi$  8mm Dovetail Stem to meet with your holding device. (except Model PC-1BW, PC-1LW)

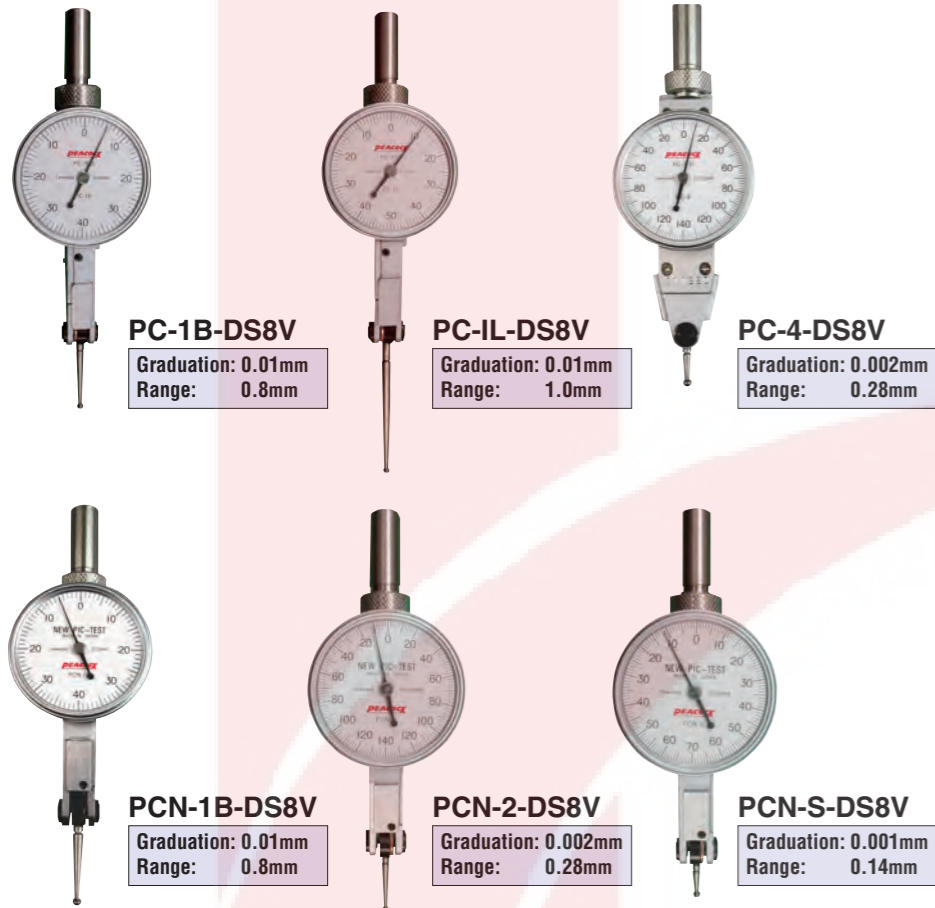

Set in Case

### Example

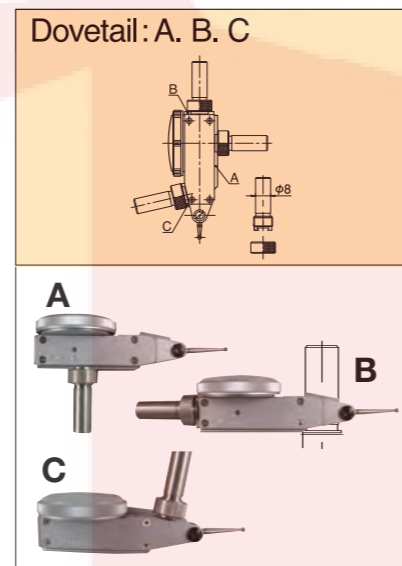

## Right Angle Contact Point for PIC TEST (PAT.No.3065810)

### Unique Contact Point not existing before! Contact Point Part No. XPILX-2

A Contact Point end bent at a right has made it possible to make a measurement of an object that used to be impossible to measure! Set the Contact Point so that it is horizontal and perpendicular to work.

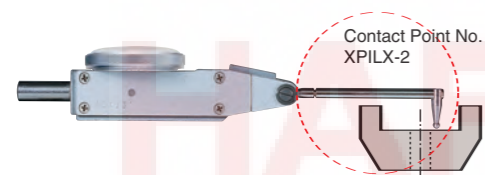

The Contact Point enable a measurement of a recessed portion located at the back of a project portion that would not be possible by the use of an existing Contact Point.

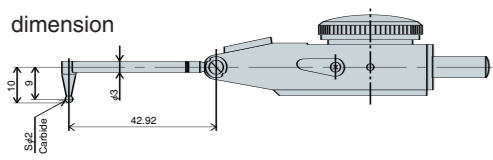

with Contact Point XP1LX-2  
Also makes it possible to measure the parallelism and run-out of grooves on different levels.

## Accessories (Option)

### ● Replaceable contact point (carbide ball)



### ● Pic test holder

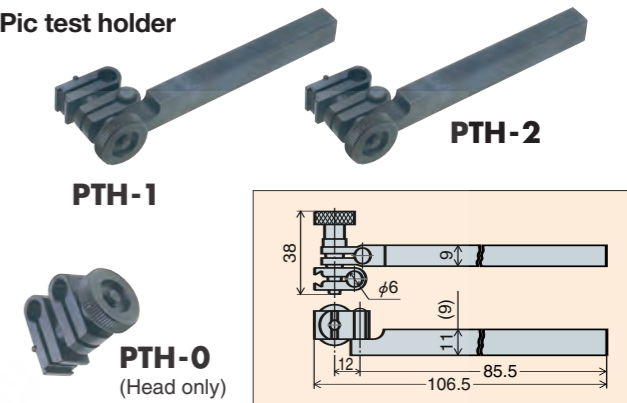

PTH-1 • 2 ( ) PTH-2

### ● Universal holder

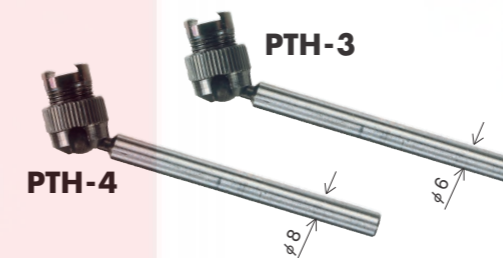

PTH-3 • 4 ( ) PTH-4

### ● Dovetail stem

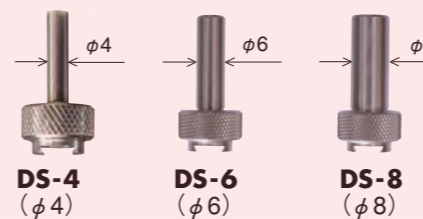

### ● Centricator (Pic Test Indicators supplied on request)

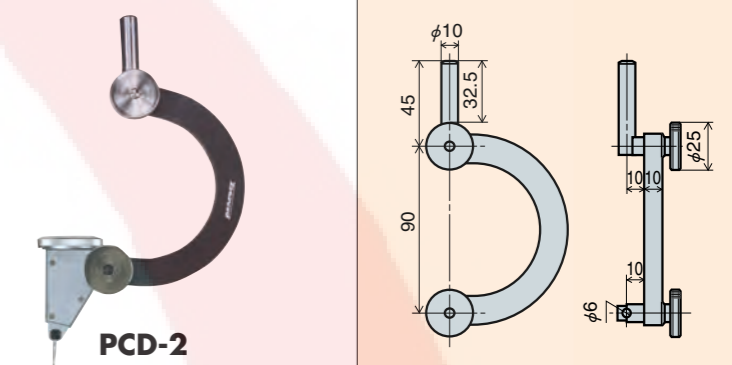

### with fine adjustment

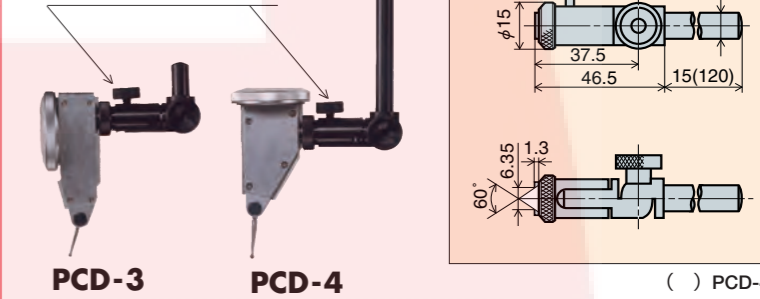

( ) PCD-4

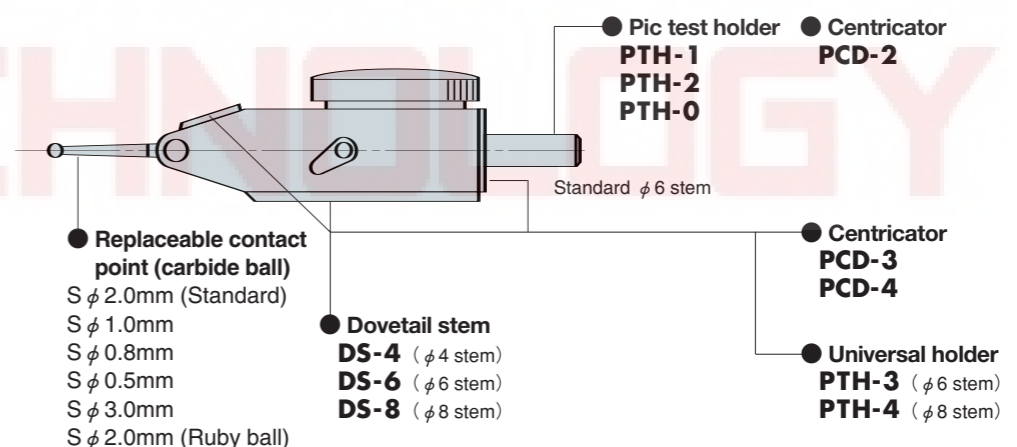

# Replaceable Contact Points (M1.7 × 0.35)

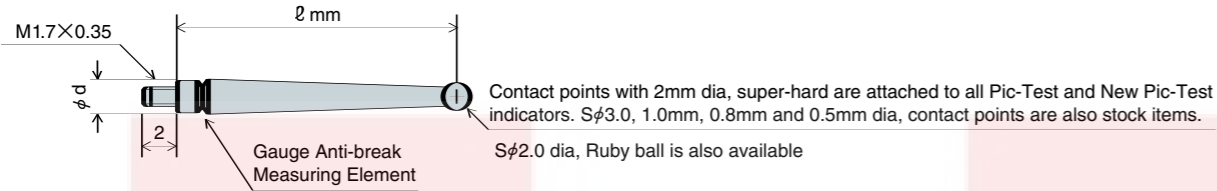

## For Pic Test (Change lever type)

Part No.	ℓ (mm)	φ ball (mm)	φ d (mm)	Applicable Indicator
XP1A-3	18.2	3	2.5	PC-1A PC-1AE PC-3
XP1A-2	18.2	2	2.5	PC-1A PC-1AE PC-3
XP1A-2R (ruby ball)	18.2	2	2.5	PC-1A PC-1AE PC-3
XP1A-1	18.2	1	2.5	PC-1A PC-1AE PC-3
XP1A-08	18.2	0.8	2.5	PC-1A PC-1AE PC-3
XP1A-05	18.2	0.5	2.5	PC-1A PC-1AE PC-3
XP1B-3	19.24	3	2.5	PC-1B PC-1BE PC-1BW
XP1B-2	19.24	2	2.5	PC-1B PC-1BE PC-1BW
XP1B-2R (ruby ball)	19.24	2	2.5	PC-1B PC-1BE PC-1BW
XP1B-1	19.24	1	2.5	PC-1B PC-1BE PC-1BW
XP1B-08	19.24	0.8	2.5	PC-1B PC-1BE PC-1BW
XP1B-05	19.24	0.5	2.5	PC-1B PC-1BE PC-1BW
XP1L-3	39.72	3	3.0	PC-1L PC-1LE PC-3L
XP1L-2	39.72	2	3.0	PC-1L PC-1LE PC-3L
XP1L-2R (ruby ball)	39.72	2	3.0	PC-1L PC-1LE PC-3L
XP1L-1	39.72	1	3.0	PC-1L PC-1LE PC-3L
XP1L-08	39.72	0.8	3.0	PC-1L PC-1LE PC-3L
XP1L-05	39.72	0.5	3.0	PC-1L PC-1LE PC-3L
XP2-3	8.80	3	2.2	PC-2 PC-4
XP2-2	8.80	2	2.2	PC-2 PC-4
XP2-2R (ruby ball)	8.80	2	2.2	PC-2 PC-4
XP2-1	8.80	1	2.2	PC-2 PC-4
XP2-08	8.80	0.8	2.2	PC-2 PC-4
XP2-05	8.80	0.5	2.2	PC-2 PC-4

## For New Pic Test (without Change lever type)

Part No.	ℓ (mm)	φ ball (mm)	φ d (mm)	Applicable Indicator
XN1A-3	17.74	3	2.5	PCN-1A PCN-0 PCN-1AE PCN-1AD PCN-5 PCN-7A
XN1A-2	17.74	2	2.5	PCN-1A PCN-0 PCN-1AE PCN-1AD PCN-5 PCN-7A
XN1A-2R (ruby ball)	17.74	2	2.5	PCN-1A PCN-0 PCN-1AE PCN-1AD PCN-5 PCN-7A PCN-1AU PCN-5U
XN1A-1	17.74	1	2.5	PCN-1A PCN-0 PCN-1AE PCN-1AD PCN-5 PCN-7A
XN1A-08	17.74	0.8	2.5	PCN-1A PCN-0 PCN-1AE PCN-1AD PCN-5 PCN-7A
XN1A-05	17.74	0.5	2.5	PCN-1A PCN-0 PCN-1AE PCN-1AD PCN-5 PCN-7A
XN1B-3	18.63	3	2.5	PCN-1B PCN-1BE PCN-1BZ (A).(B)
XN1B-2	18.63	2	2.5	PCN-1B PCN-1BE PCN-1BZ (A).(B)
XN1B-2R (ruby ball)	18.63	2	2.5	PCN-1B PCN-1BE PCN-1BU PCN-1BZ (A).(B)
XN1B-1	18.63	1	2.5	PCN-1B PCN-1BE PCN-1BZ (A).(B)
XN1B-08	18.63	0.8	2.5	PCN-1B PCN-1BE PCN-1BZ (A).(B)
XN1B-05	18.63	0.5	2.5	PCN-1B PCN-1BE PCN-1BZ (A).(B)
XN1L-3	39.00	3	2.5	PCN-1L PCN-1LE PCN-1LD PCN-1LZ (A).(B)
XN1L-2	39.00	2	2.5	PCN-1L PCN-1LE PCN-1LD PCN-1LZ (A).(B)
XN1L-2R (ruby ball)	39.00	2	2.5	PCN-1L PCN-1LE PCN-1LD PCN-1LU PCN-1LZ (A).(B)
XN1L-1	39.00	1	2.5	PCN-1L PCN-1LE PCN-1LD PCN-1LZ (A).(B)
XN1L-08	39.00	0.8	2.5	PCN-1L PCN-1LE PCN-1LD PCN-1LZ (A).(B)
XN1L-05	39.00	0.5	2.5	PCN-1L PCN-1LE PCN-1LD PCN-1LZ (A).(B)
XN2-3	14.33	3	2.2	PCN-2 PCN-2E PCN-6 PCN-2Z (A).(B) PK-TEST
XN2-2	14.33	2	2.2	PCN-2 PCN-2E PCN-6 PCN-2Z (A).(B) PK-SA PK-SB
XN2-2R (ruby ball)	14.33	2	2.2	PCN-2 PCN-2E PCN-6 PCN-2U PCN-6U PCN-2Z (A).(B) PK-SAR PK-SBR
XN2-1	14.33	1	2.2	PCN-2 PCN-2E PCN-6 PCN-2Z (A).(B) PK-TEST
XN2-08	14.33	0.8	2.2	PCN-2 PCN-2E PCN-6 PCN-2Z (A).(B) PK-TEST
XN2-05	14.33	0.5	2.2	PCN-2 PCN-2E PCN-6 PCN-2Z (A).(B) PK-TEST
XN2B-3	13.00	3	2.2	PCN-2B PCN-2BD PCN-7C PCN-SD
XN2B-2	13.00	2	2.2	PCN-2B PCN-2BD PCN-7C PCN-SD
XN2B-2R (ruby ball)	13.00	2	2.2	PCN-2B PCN-2BD PCN-7C PCN-SD PCN-2BU
XN2B-1	13.00	1	2.2	PCN-2B PCN-2BD PCN-7C PCN-SD
XN2B-08	13.00	0.8	2.2	PCN-2B PCN-2BD PCN-7C PCN-SD
XN2B-05	13.00	0.5	2.2	PCN-2B PCN-2BD PCN-7C PCN-SD
XNS-3	8.13	3	2.2	PCN-S
XNS-2	8.13	2	2.2	PCN-S
XNS-2R (ruby ball)	8.13	2	2.2	PCN-S PCN-SU
XNS-1	8.13	1	2.2	PCN-S
XNS-08	8.13	0.8	2.2	PCN-S
XNS-05	8.13	0.5	2.2	PCN-S

# Dimensions of Lever Type Dial Indicators

## Contact Points Length and Types

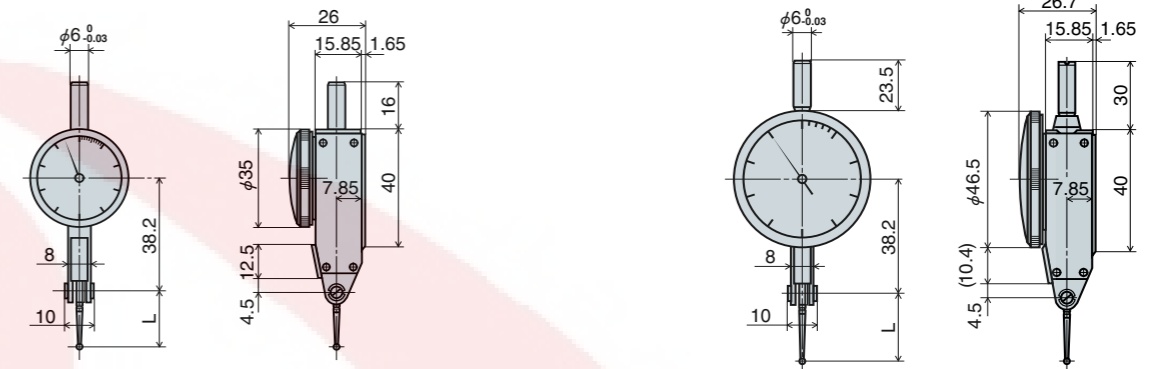

Model	L (mm)
PCN-1A . PCN-1AE . PCN-1AU . PCN-7A	21.3
PCN-1B . PCN-1BE . PCN-1BU . PCN-1BZ(A)(B)	22.2
PCN-1L . PCN-1LE . PCN-1LU . PCN-1LZ(A)(B)	42.8
PCN-2 . PCN-2E . PCN-2U . PCN-2Z(A)(B)	17.94
PCN-2B . PCN-2BU	16.6
PCN-S	11.7
PCN-7C	16.6

Model	L (mm)
PCN-1AD	21.3
PCN-2BD . PCN-SD	16.6
PCN-1LD	42.8

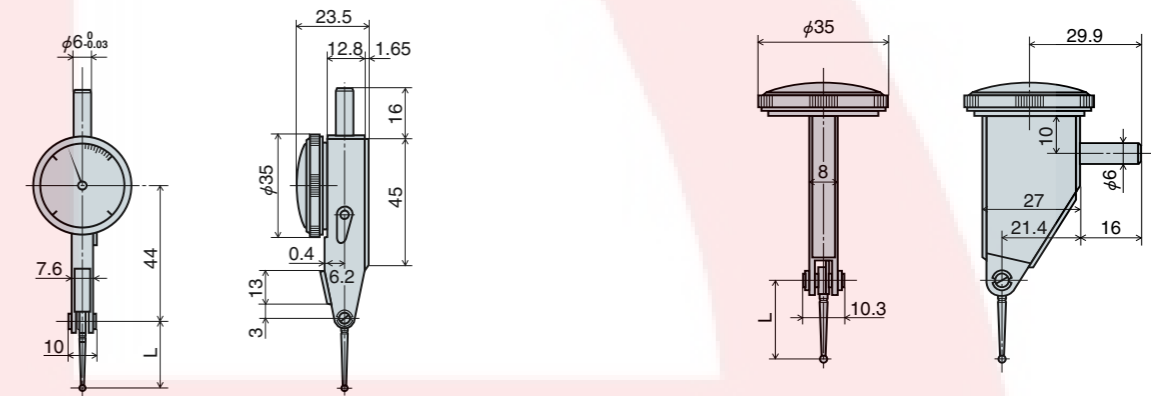

Model	L (mm)
PC-1A . PC-1AE	21.4
PC-1B . PC-1BE	22.4
PC-1L . PC-1LE	43.0
PC-2	12.0

Model	L (mm)
PCN-5 . PCN-5U	21.3
PCN-6 . PCN-6U	17.94

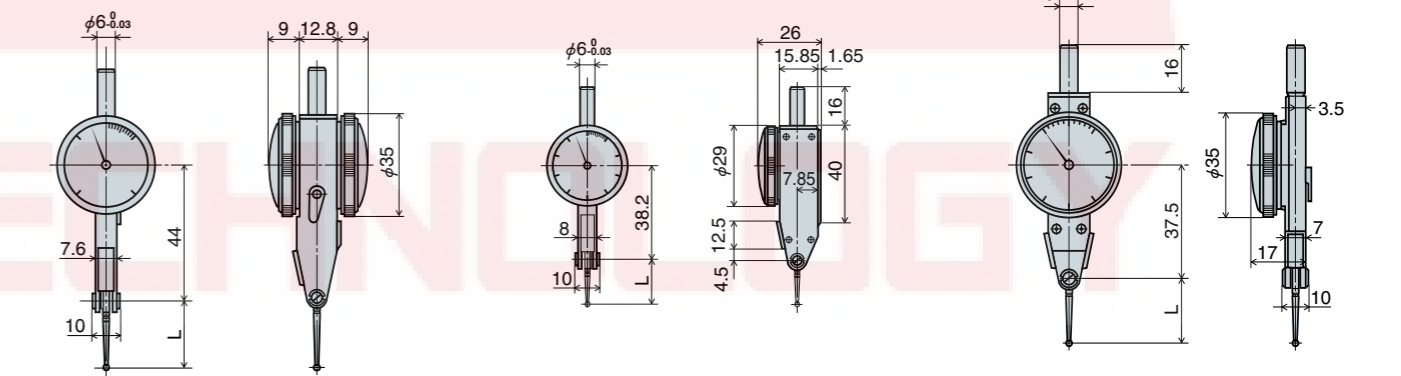

Model	L (mm)
PC-1BW	22.4

Model	L (mm)
PCN-0	21.3

Model	L (mm)
PC-3	21.4
PC-4	12.0
PC-3L	43.0

Dimensions of Lever Type Dial Indicators

Replaceable Contact Points (M1.7 × 0.35)

# Applied Examples

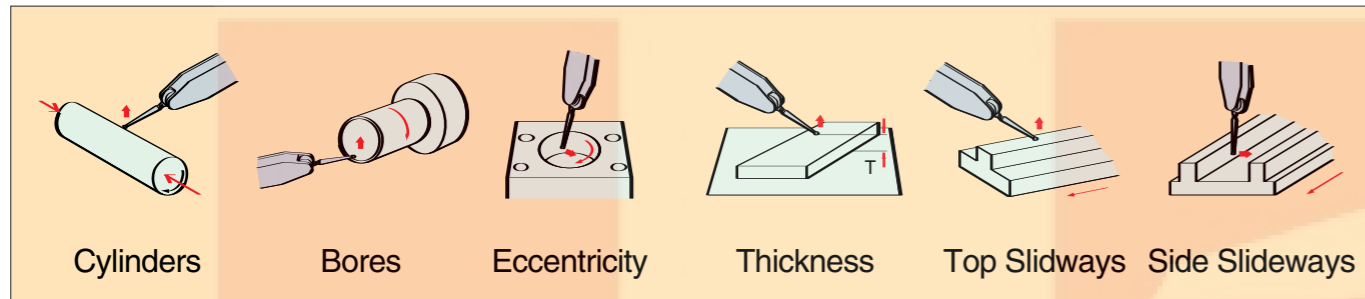

## Precautions for Handling

- Dial gauges shall be used by being fixed to a rigid retainer to prevent the influence of flexure or the like. In measurement, the measuring direction shall be made perpendicular to the center line of the measuring probe.

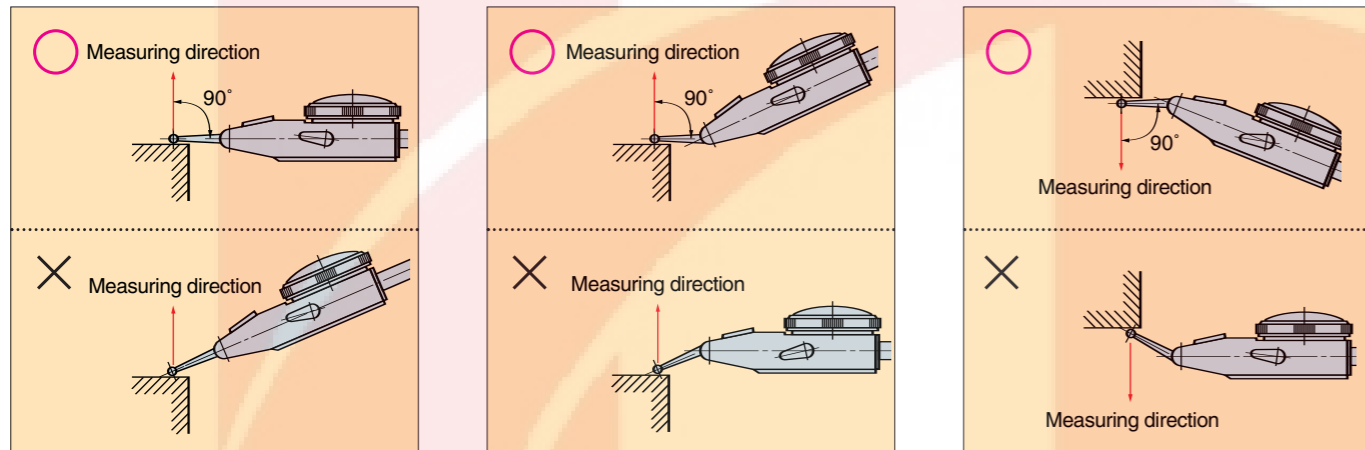

- In case they are not perpendicular, a correction by the following formula is necessary:** Due to various measuring direction, the contact point sometimes can not be angled perpendicular to the measuring device.

Examples the diagrams below, where the measuring probe is set at a non-perpendicular angles and the distance between the pivot of the contact point and the measuring device is signified by the letter H:

Displacement = quantity of pointer movement x COS  $\theta$

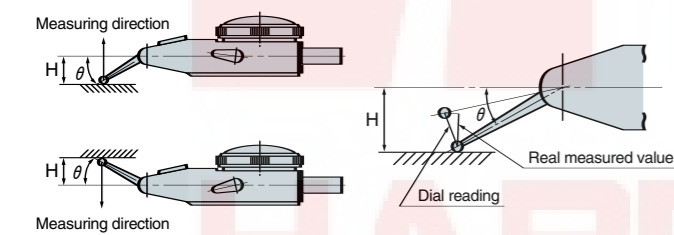

**Example:**  
Using a PC-1A indicator, suppose the degree of angle is 30° and the Pic Test reading is 0.05mm. The factor for the PC-1A indicator from the graph is 0.87.  
 $0.05\text{mm} \times 0.87 = 0.0435 = 0.043\text{mm}$

- When modification is not necessary:** If the measuring tolerance is 10% and the graph factor is above 0.9, modification by calculation is unnecessary.

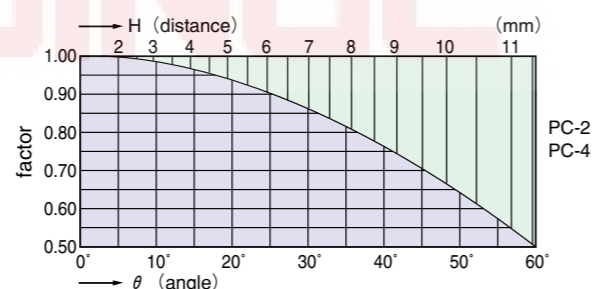
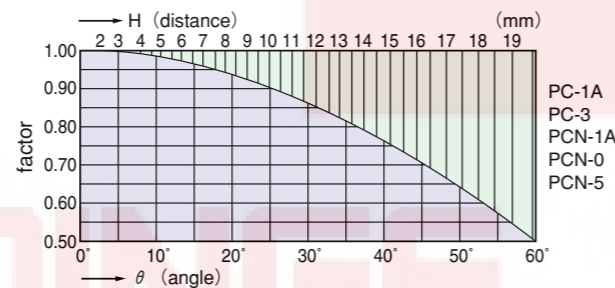

# Lever type Dial Indicator

New

## PK-TEST

### World's first 0.001mm Graduation Lever type Indicator with Long Contact Point (14.18mm).

- It is possible to enable the longer contact point by New Mechanism. (Utility Model Registration No.3206149)
- Longer Contact Point can be reached your measurement work-piece.
- Contact Point is selectable "Carbide ball" or "Ruby ball".

### Upward direction measurement

- Model No. PK-SA (with dia. 2mm Carbide ball)
- Model No. PK-SAR (with dia. 2mm Ruby ball)

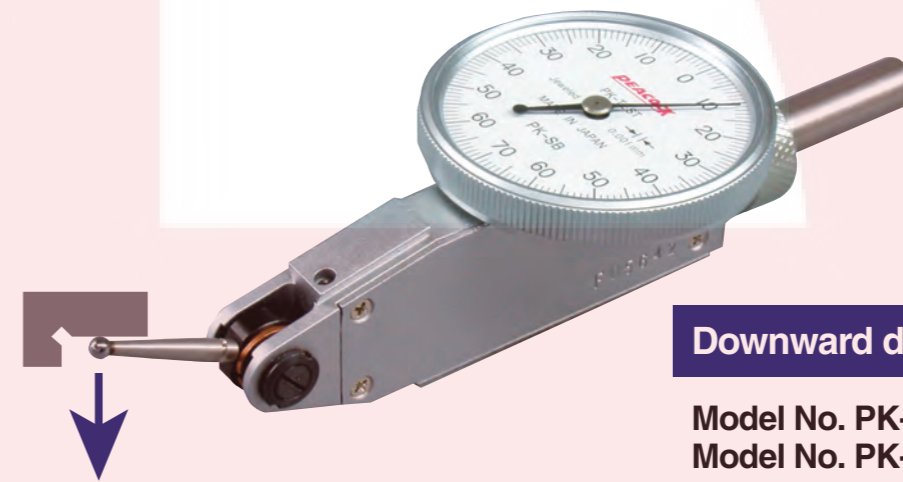
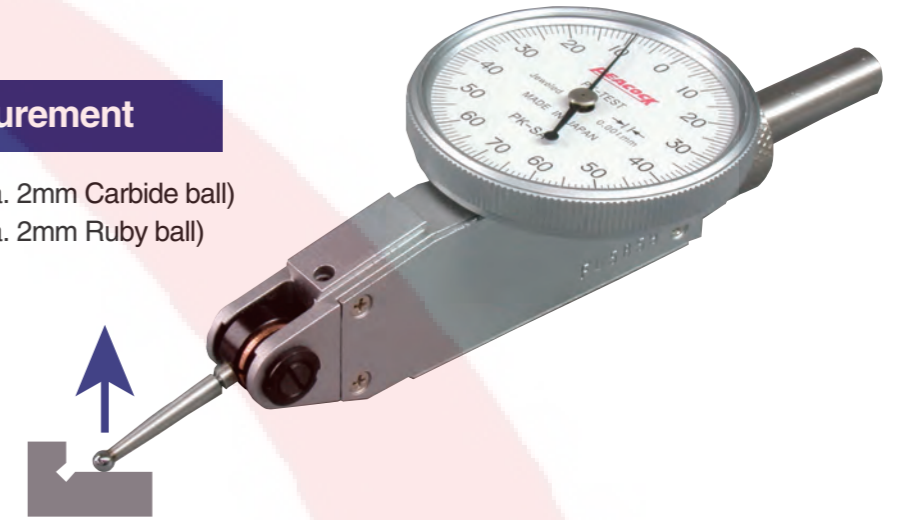

### Downward direction measurement

- Model No. PK-SB (with dia. 2mm Carbide ball)
- Model No. PK-SBR (with dia. 2mm Ruby ball)

### Specifications

Model	Contact Point	Direction of Measurement	Graduation (mm)	Range (mm)	Wide-range forward accuracy ( $\mu\text{m}$ )	10 scale indication error ( $\mu\text{m}$ )	Hysteresis ( $\mu\text{m}$ )	Repeatability ( $\mu\text{m}$ )	Accessory
PK-SA	Carbide	Upward	0.001	0.14	4.0	2.0	3.0	1.0	Dovetail Stem $\phi$ 6mm (DS-6)
PK-SAR	Ruby								
PK-SB	Carbide	Downward							
PK-SBR	Ruby								

Please purchase PK series after checking the direction of your measurement. (PK series has no change Lever and no function to change direction automatically.)

# Lever type Dial Indicator

## PK-TEST

### Certificate of Inspection is attached.

We attach Certificate of Inspection at the time of inspection.

CERTIFICATE OF INSPECTION 検査成績書	
Product Name : PK-TEST	Measuring range : 0.5mm
Model : PC-1A	Scale interval : 0.01mm
Serial No. : P10082	Temperature : 20°C~27°C
Inspection standard : JIS B 7533-2015	Relative humidity : 40%~70%
許容誤差 (Permissible error) $\mu\text{m}$	測定誤差 (Measuring Error)
全周長測定 (全周長測定) Accuracy	5.0
10日経過後 (10日経過後) 1/10 rev.	5.0
10日経過後 (10日経過後) 1 rev.	1.2
200回 (200回) Hysteresis	4.0
繰返し (繰返し) Repeatability	3.0
判定 (判定) Judgment	合格 (合格) Passed

OZAKI MFG. CO., LTD.

Attached Certificate of Inspection cannot be used as Calibration Certificate. Apply for Calibration Certificate when you Purchase products.

### Crystal is formed by press-molding special acrylic plate.

Special acrylic plate is superior to injection molding material in "Oil-proof", "Chemical resistance" and "Transparency" and it is formed by a press work as convex R shape.

### Hold by Dovetail Stem.

Dovetail Stem can be hold by 3 positions dovetail groove. (Upper, Lower and Back side positions.) There are 3 kinds of diameter  $\phi 4$ ,  $\phi 6$  and  $\phi 8\text{mm}$ . (PK series is including  $\phi 6\text{mm}$  as standard but you can choose  $\phi 4$  or  $\phi 8\text{mm}$ .)

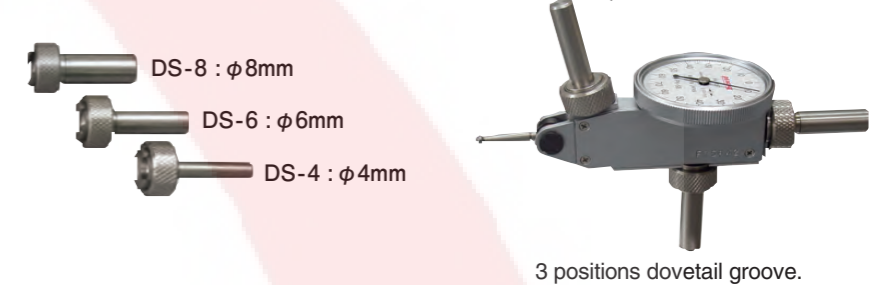

### Protect "Crystal" by Bezel made of Metal.

Bezel is made of Metal, it prevents "Crystal" from damage and deformation. Even if a scratch is generated on Crystal, it is easy to exchange only "Crystal". There is no aged deterioration on Bezel made of Metal and even if using for a long time, it would be easy to turn Bezel and adjust Zero setting smoothly.

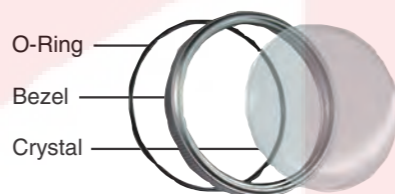

### Even if using for long hours, white color of Dial Plate is comfort on the eyes.

Dial Plate based on white color allows an easy view of Pointer and reducing fatigue of the eyes.



### Prevent looseness by 3 points screws.

In PK series, adapt new body and base metal for 3 points fixing screws, which more strengthens the fixing force.

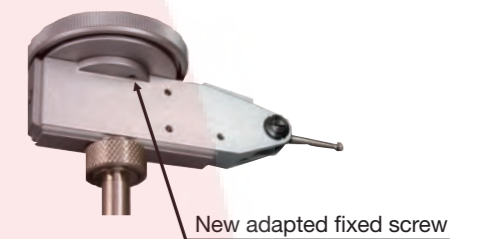

### Contact Point gets Longer.

PK-TEST enables 6.05mm longer than the conventional 0.001mm Graduation type.



### Contact Point with groove of anti-break.

When a force is applied to Contact Point, it is bent at the groove to protect body and only exchange broken Contact Point. (Apply to all our Pic Test Indicators)

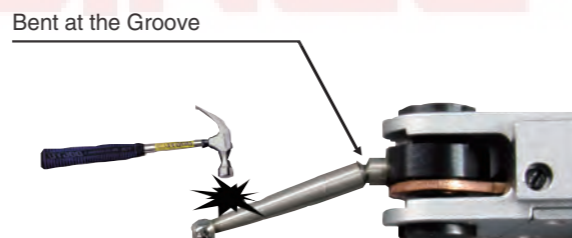

### Lever supporting point is used with Pivot bearing with both left and right side

Unique structure using Pivot bearing used with both side of left and right is high reliable and keeps high repeatability even if using for a long time. (Apply to all Pic Test indicators)

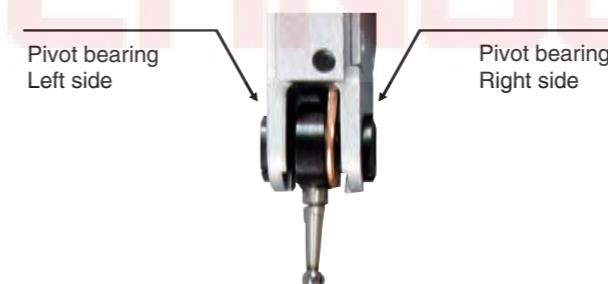

### Mechanism with easy maintenance even using for a long time.

It is possible to repair by the same movement method of a clock and keeping durability of bearing due to Jewel. (Apply to all Pic Test Indicators)

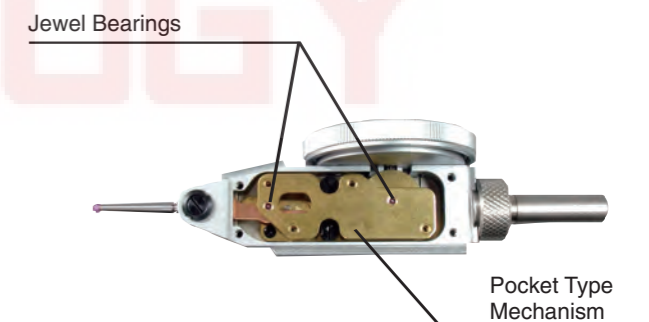

# Lever type Dial Indicator

## PK-TEST

### Upward Measurement

PK-SA  
PK-SAR

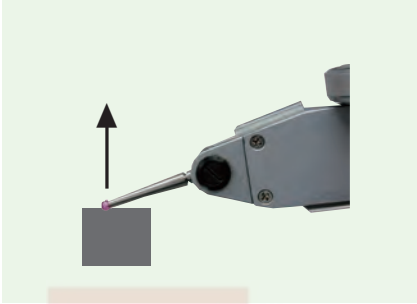

### Contact Point (Carbide)

for PK-SA  
for PK-SB



### Dovetail Stem

Standard Accessory : DS-6  
Option : DS-4 and DS-8

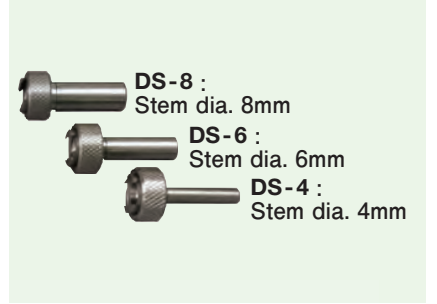

### Downward Measurement

PK-SB  
PK-SBR

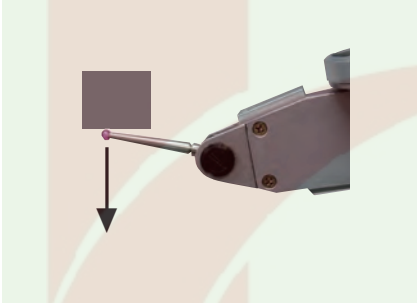

### Contact Point (Ruby)

for PK-SAR  
for PK-SBR

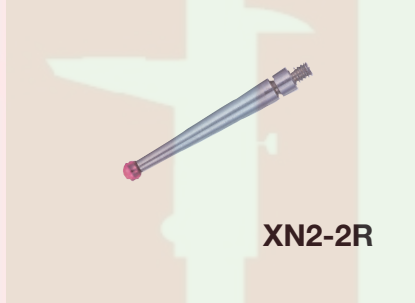

### Mounting Position of Dovetail Stem



### Dimensions

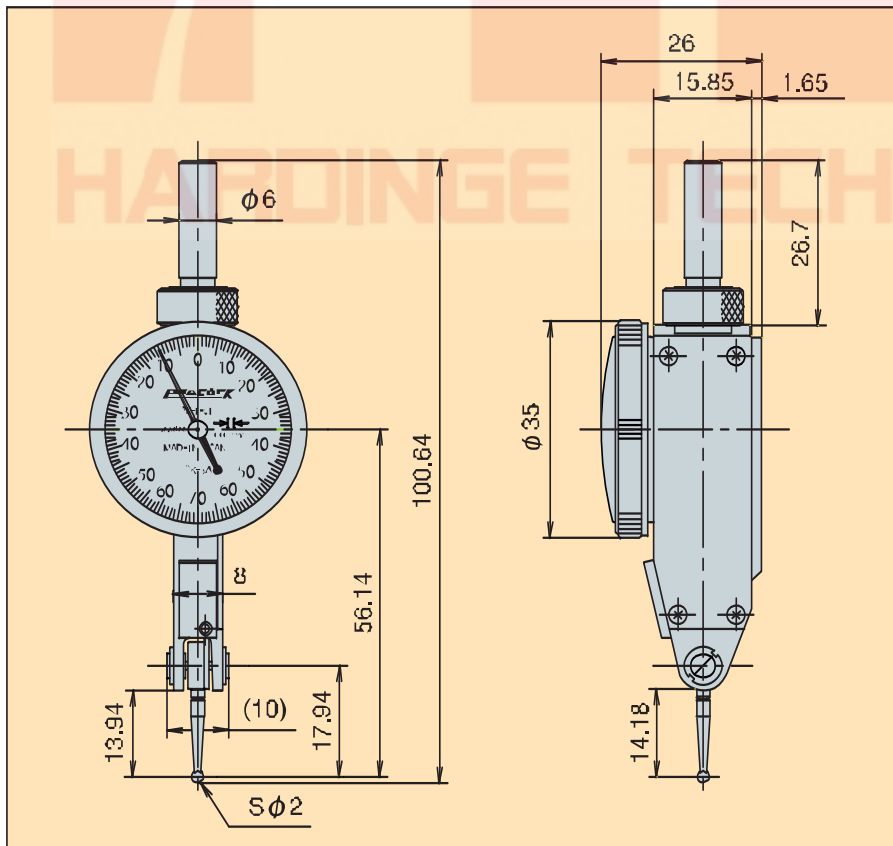

### Replaceable Contact Points

